

PLAN VIEW

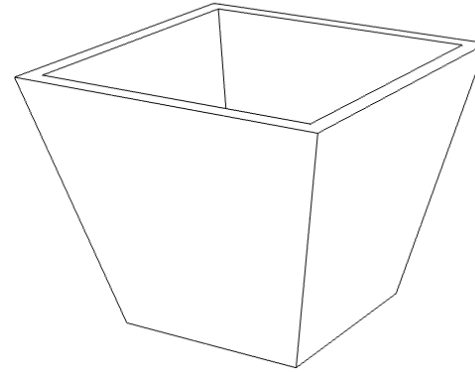

PERSPECTIVE

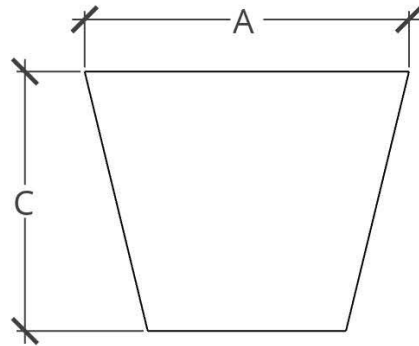

FRONT ELEVATION

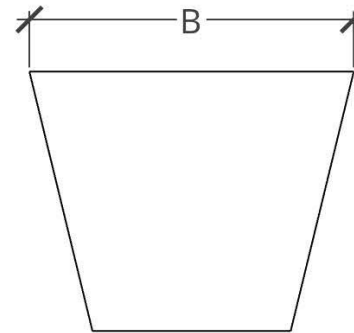

SIDE ELEVATION

**HCD**  
HART CONCRETE DESIGN

**TO SPECIFY:**

Hart Concrete Design  
2120 South Susan Street  
Santa Ana, CA 92704  
866.716.4278  
www.hartconcretedesign.com

Item: COSTA PLANTER

**Size:**

- 15" X 15" X 12"H
- 22 1/2" X 22 1/2" X 18"H
- 30" X 30" X 24"H
- 43 1/4" X 43 1/4" X 30"H

**Select Desired Color:**

- GREY
- IRON
- STEEL
- WHITE
- MALIBU
- MESA

**Select Desired Finish:**

- SMOOTH
- TRAVERTINE

**Drain Hole:**

- YES
- NO

**Tar:**

- YES
- NO

DIMENSIONS	LIP SIZE	WEIGHT
15" X 15" X 12"H	1"	75 LBS
22 1/2" X 22 1/2" X 18"H	1 1/4"	150 LBS
30" X 30" X 24"H	1 1/4"	275 LBS
43 3/4" X 43 3/4" X 30"H	1 1/4"	500 LBS

**NOTE**  
 1. Installation to be completed in accordance with manufacturer's specifications  
 2. Do not scale this drawing.  
 3. This drawing is intended for use by architects, engineers, contractors, consultants and design professionals for planning purposes only. This drawing may not be used for construction.  
 4. All information contained herein was current at the time of development but must be reviewed and approved by the product manufacturer to be considered accurate.