

HCD

Hart Concrete Design
(866) 716-4278

Item: BOARDFORM QUADRA
Gas Type: NATURAL GAS
Ignition: PUSH BUTTON
Date: 12/07/2022

- Size:**
- 36" X 36" X 18"H
 - 42" X 42" X 18"H
 - 48" X 48" X 18"H
 - 54" X 54" X 18"H

- Select Desired Color:**
- WHITE
 - GREY
 - IRON
 - STEEL
 - MALIBU
 - IDAHO
 - MESA

- Accessories (incurs additional charge):**
- WINDGUARD
 - MIXED FIREBALLS
 - UNIFORM FIREBALLS
 - FIRE GLASS
 - CANVAS COVER
 - POLISHING SPRAY

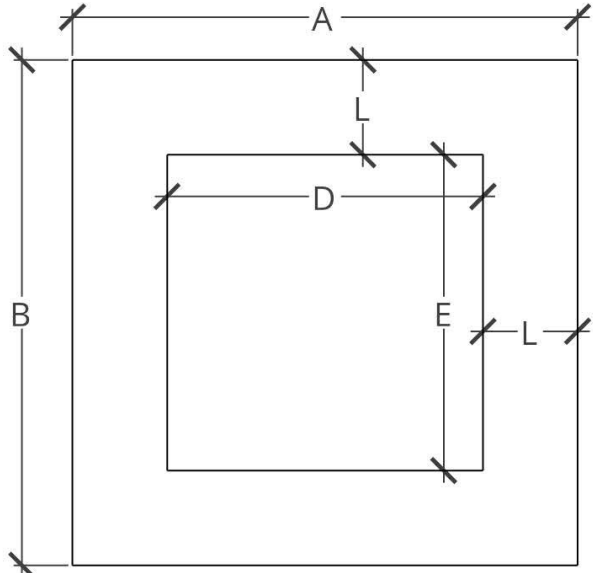

PLAN VIEW

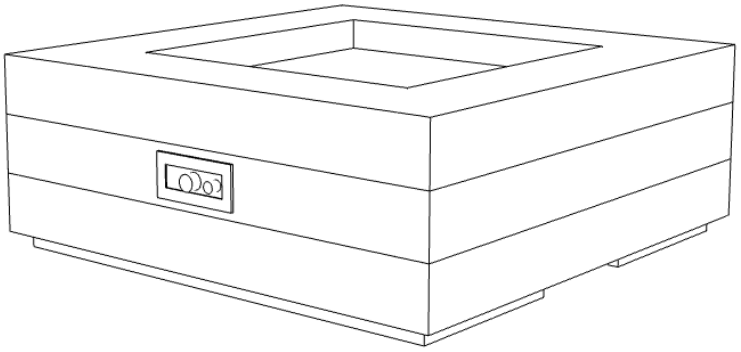

PERSPECTIVE

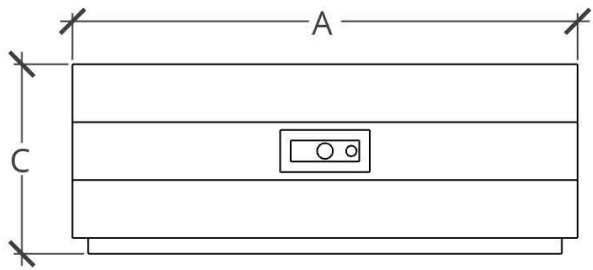

FRONT ELEVATION

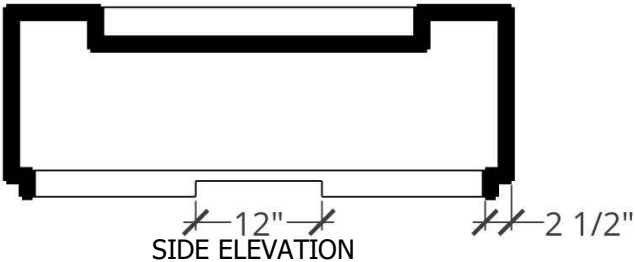

SIDE ELEVATION

DIMENSIONS (A X B X C)	LEDGE (L)	BURNER AREA (D X E)	WEIGHT	BURNER	BTU RATING
36" X 36" X 18"H	6"	24" X 24"	300 LBS	FPPK18-SQ-FLEX-NG	65K
42" X 42" X 18"H	9"	24" X 24"	350 LBS	FPPK18-SQ-FLEX-NG	65K
48" X 48" X 18"H	9"	30" X 30"	400 LBS	FPPK24-SQ-FLEX-NG	90K
54" X 54" X 18"H	12"	30" X 30"	500 LBS	FPPK24-SQ-FLEX-NG	90K

HCD

Hart Concrete Design
(866) 716-4278

Item: BOARDFORM QUADRA
Gas Type: NATURAL GAS
Ignition: PUSH BUTTON
Date: 12/07/2022

- Size:**
- 60" X 60" X 18"H
 - 66" X 66" X 18"H
 - 72" X 72" X 18"H
 - OTHER: _____

- Select Desired Color:**
- WHITE
 - GREY
 - IRON
 - STEEL
 - MALIBU
 - IDAHO
 - MESA

- Accessories (incurs additional charge):**
- WINDGUARD
 - MIXED FIREBALLS
 - UNIFORM FIREBALLS
 - FIRE GLASS
 - CANVAS COVER
 - POLISHING SPRAY

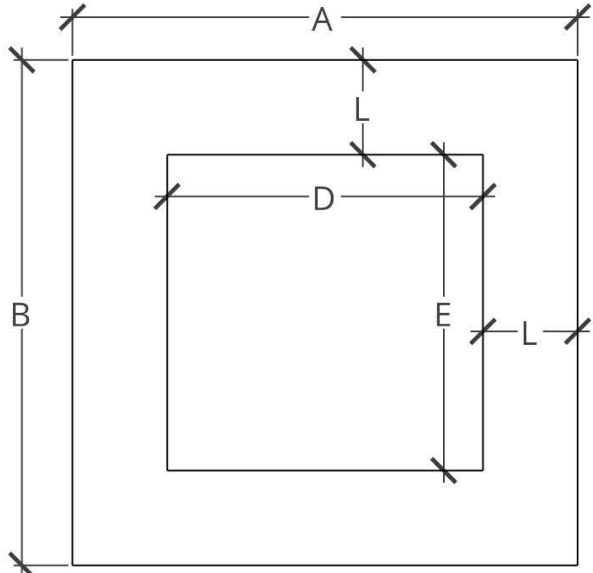

PLAN VIEW

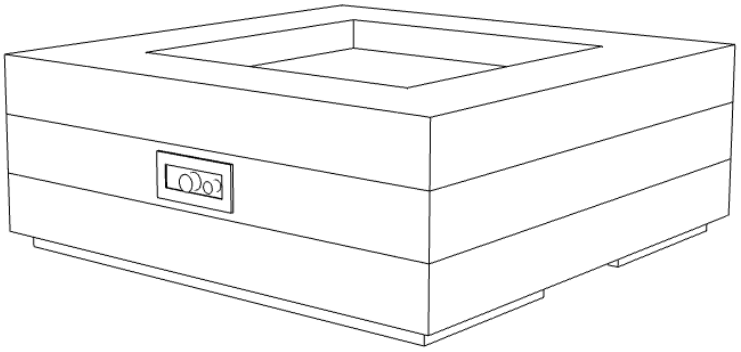

PERSPECTIVE

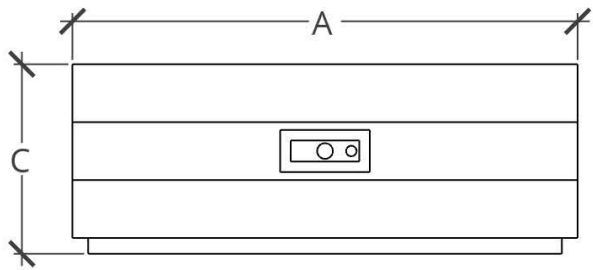

FRONT ELEVATION

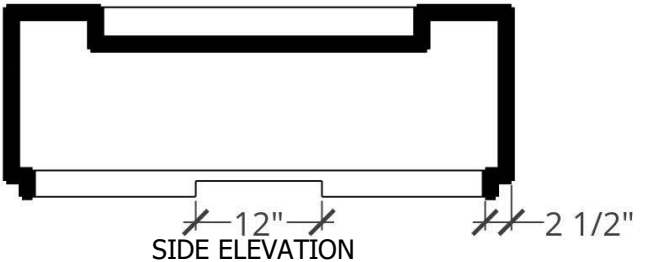

SIDE ELEVATION

DIMENSIONS (A X B X C)	LEDGE (L)	BURNER AREA (D X E)	WEIGHT	BURNER	BTU RATING
60" X 60" X 18"H	12"	36" X 36"	550 LBS	FPPK30-SQ-FLEX-NG	140K
66" X 66" X 18"H	12"	42" X 42"	650 LBS	FPPK36-SQ-FLEX-NG	140K
72" X 72" X 18"H	12"	48" X 48"	750 LBS	FPPK36-SQ-FLEX-NG	140K